

Name: _____

USC ID#: _____

I hereby affirm that all the answers below are my own. I have neither searched online nor taken assistance from any external entity.

Student Signature Above

EE105 – Fall 2025 Practice Final

Time Limit: 2 hours

Section 1: /25

Section 2: /25

Section 3: /25

Section 4: /25

Total: /100

Advice: If you find a question difficult, move on to the next and come back to the difficult one after finishing other easy questions

Section A (25 points)**Question 1 (4 points)**

The circuit below includes a thermistor. Solve the equation for R_T (thermistor resistance). The solution should be expressed as a function of V_{out} .

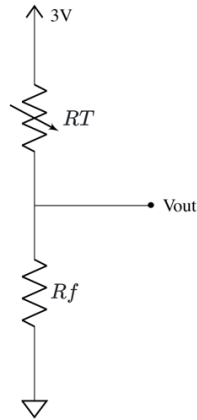
**Question 2 (3 points)**

An operational amplifier (Op-Amp) is connected to two distinct resistor networks as illustrated below. Calculate the output voltage (V_{out}). Assume that the amplification factor (A) is equal to 1.

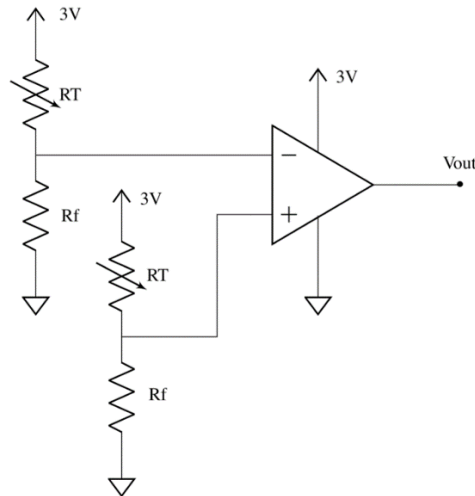

Question 3 (4 points)

An operational amplifier (Op-Amp) is connected with resistors as shown below. Derive the expression for the output voltage (V_{out}) in terms of the input voltage (V_{in}).

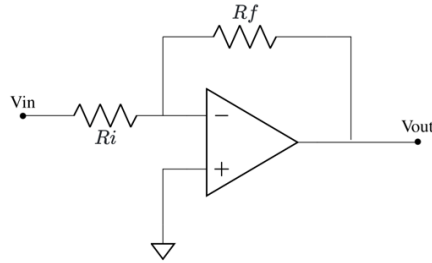
**Question 4 (6 points)**

Two operational amplifiers (Op-Amps) are connected in a cascaded configuration as illustrated in the circuit below. Derive the expression for the output voltage (V_{out}) in terms of the input voltage (V_{in}).

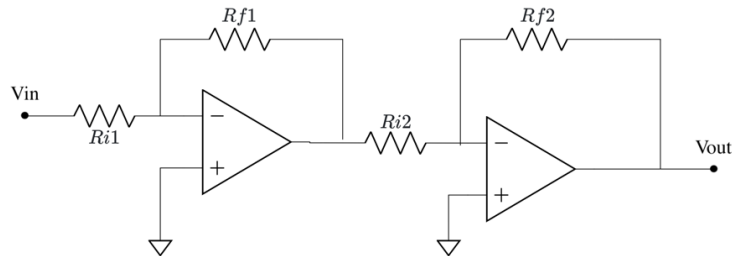

Question 5 (3 points)

Remember the oximeter from your demo board used during the class? Identify all the systems involved in capturing data from the physical world and displaying it on a computer. Fill in the provided blank blocks to complete the system diagram.

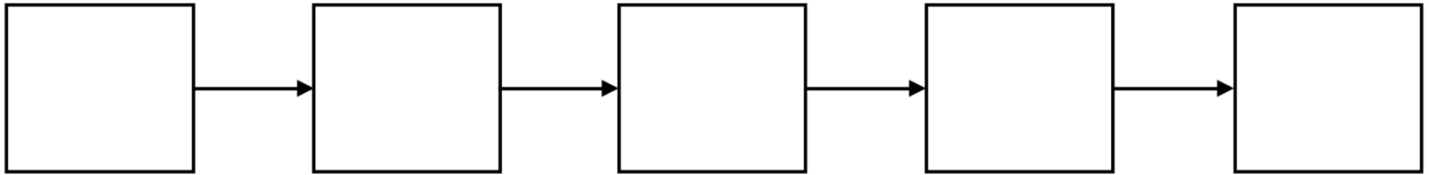
**Question 6 (3 points)**

Using the provided information, calculate the oxygenation (SpO₂) of the person:

Red_{AC} = 40mV, Red_{DC} = 600mV, NIR_{AC} = 20mV, and NIR_{DC} = 300mV

SpO₂ = 110 - 25 x ROS, determine if the person requires supplemental oxygen based on the calculated SpO₂?

Question 7 (2 points)

How many LEDs are required for the oximeter with oxy- and dexoy-hemoglobin optical absorbance depicted in the graph? Explain your rationale.

Section B (25 points)**Question 8 (2 points)**

The diagram shows the frequency response of a signal. To isolate a frequency of 20 Hz, what type of filter would you use?

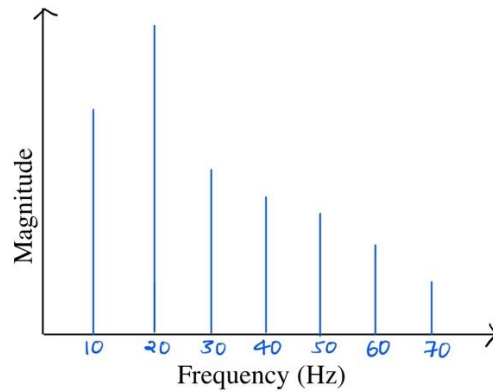
**Question 9 (8 points)**

A circuit contains two diodes, each with a threshold voltage of $V_t = 0.7$ V. The diodes are forward-biased and connected in series. The anode of the first diode is connected to the positive terminal of a 3.3 V battery. The cathode of the first diode is connected to the anode of the second diode. The cathode of the second diode is connected to the negative terminal of the battery through a wire.

The wire connecting the cathode of the second diode to the battery has a length of 1 m, a diameter of $200 \mu\text{m}$, and a resistivity of $\rho = 1.7 \times 10^{-8} \Omega \cdot \text{m}$. Assume the diodes are ideal apart from the threshold voltage.

1. Draw the circuit diagram.
2. Calculate the current flowing through the wire.

Question 10 (15 points)

An optical detector system consists of:

- A photodiode operating at reverse bias of 5V
- A resistor for converting current to voltage with resistance of $50\text{k}\Omega$
- Incident light producing $2\mu\text{A}$ of photocurrent

Calculate: a) The output voltage of the resistor

b) The RMS noise voltage if the system bandwidth is 1MHz and the photodiode dark current is 1nA. Consider the noise current sources to be thermal noise, shot noise from the photocurrent, and shot noise from the photodiode dark current.

c) The signal-to-noise ratio (not in DB, just the ratio)

Name: _____

USC ID#: _____

Section C (25 points)**Question 11 (5 points)**

Draw a simple neuron, show input and output channels, and explain the activation function. What are the different activation functions and their pros and cons?

Question 12 (5 points)**Design a Neural Network Topology**

- Design a neural network to classify whether a person should attend a UCLA vs USC game. The inputs are:
 - Probability of Trojans winning (very good or good)
 - Availability of tickets (yes or no)
 - Friends attending (yes or no)
- Specify the number of inputs, weights, activation function, and output for this simple model.

Question 13 (15 points)

Design single-neuron perceptron with step activation for AND, OR, and NAND gates:

$$y = f(w_1x_1 + w_2x_2 + b), \text{step}(z) = \begin{cases} 1, & z \geq 0 \\ 0, & z < 0 \end{cases}$$

with Boolean inputs $x_1, x_2 \in \{0,1\}$.

Truth tables (reference)

AND

x_1	x_2	AND
0	0	0
0	1	0
1	0	0
1	1	1

OR

x_1	x_2	OR
0	0	0
0	1	1
1	0	1
1	1	1

NAND

x_1	x_2	NAND
0	0	1
0	1	1
1	0	1
1	1	0

(a) Perceptron for AND (single neuron)

- Write the four inequalities on w_1, w_2, b implied by the AND table using the rule:
 - If label = 1: $w_1x_1 + w_2x_2 + b \geq 0$;
 - If label = 0: $w_1x_1 + w_2x_2 + b < 0$.
- Use a symmetric choice $w_1 = w_2 = 1$ and solve for a valid interval of b .
- Provide one valid parameter triple (w_1, w_2, b) .
- Sketch the decision boundary $w_1x_1 + w_2x_2 + b = 0$ and mark which vertices are classified 1 vs. 0.

(b) Perceptron for OR (single neuron)

- Repeat part (a) for OR: write inequalities, set $w_1 = w_2 = 1$, solve for a valid b -interval, give one valid (w_1, w_2, b) , and sketch the boundary.

(c) Perceptron for NAND (single neuron)

- Using inequalities (or by flipping the AND separator), find a valid (w_1, w_2, b) for NAND.
- Briefly justify your choice and sketch the resulting boundary.

Name: _____

USC ID#: _____

Section D (25 points)

Imagine you have a green LED (emission wavelength = 532 nm), and a silicon photodetector with a responsivity as shown below.

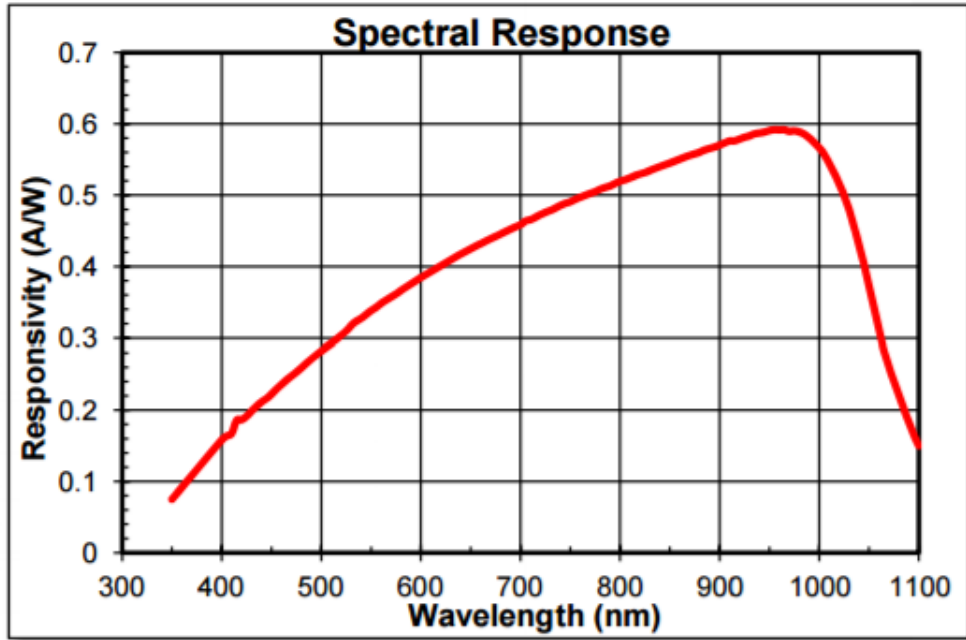

Your LED has a diode I-V curve as shown below. Assume a quantum efficiency of current to photon generation of 21.5%. For the purposes of the questions below, assume 100% of the emitted light falls on the photodetector.

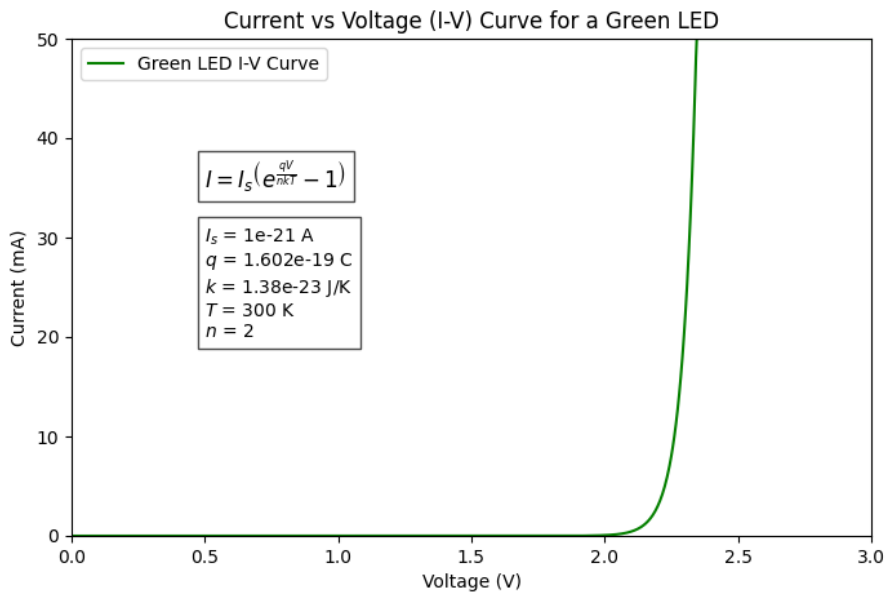

- a) Design an LED driver circuit using a tunable voltage source, a 100 Ohm resistor, and the LED. By tuning the voltage source in this circuit, you should be able to control the current in the LED. What is the minimum and maximum voltage you will need the tunable voltage source to output if you want to be able to control the current in the LED between 0 mA and 10 mA? Solve the diode equation and be precise with the voltage required. (8 points)
- b) Now use op amps, ONLY 100 ohm resistors (any number of them), and the photodetector to build a readout circuit. Assume the output of this detection circuit goes to an analog to digital converter (ADC), and this analog to digital converter can accept a maximum signal of 10 V and a minimum signal of 0 V. In order for us to maximize the use of this (ADC) we want to create a photodetector readout circuit that outputs 10 V when we are flowing max current through our LED (i.e. 10 mA). Design an amplifier circuit that outputs 10 V at max LED brightness (i.e. when flowing max current through the LED). (8 points)
- c) Write the expression for the voltage noise in a measurement bandwidth B . Compute the numerical RMS noise voltage for $B = 100$ kHz. If the same resistor is cooled to $T = 150$ K with the same B , what is the new RMS noise voltage? Comment on the scaling with T . (7 points)